

On-Road Mobile Lubrication Systems

Grease Jockey®

Features and Benefits

- Keeps your chassis operating, even in harsh on-road conditions
- Lubricant goes where it's supposed to, automatically, with little or no waste
- Field-proven—some of the largest fleets have been using Grease Jockey for decades!

Typical Applications

- Truck and tractor lubrication, class 4, 5, 6, 7, and 8 vehicles

Typical Fluids Handled

- NLGI #0, #00 or #000 Grease

Technical Specifications

Construction	Cast aluminum body and bracket
Lubricant	NLGI #0, #00 or #000 grease
Output per Cycle	1.5 cu. in (24.6 cm ³)
Reservoir Capacity	6 lbs. (2.7 kg), 12 lbs. (5.4 kg)
Inlet supply (dry) (air pump)	150 psi (1034 kPa) max; 60 psi (414 kPa) min
Air-to-lube Ratio (max.)	9:1
Solenoid Voltage (air)	12 or 24 VDC
Electrical	9 to 32 VDC (12 or 24 VDC Nominal)
Enclosure (air pump)	High-impact sealed plastic
Component Technology	Solid-state
Pump "ON" Time	Programmable: 1 sec. to 99 min.
Lube Cycle Frequency	Programmable: 1 min. to 99 hrs.
Main Supply to Modules5/16 in O.D. heavywall nylon
Module to Point3/16 in O.D. heavywall nylon
Operating Pressure (nylon lines)	1,350 psi (9,310 kPa)



	Part #	Fill Port	Solenoid	Timer/Wiring Harness Kit	Mounting Plate	Mainline and Hardware	Extra Fittings Kit
Grease Jockey Pump Kits							
Pump Only, No Reservoir	563625	Straight					
Pump with 6# Rigid Reservoir	563589	Straight					
Pump with 12# Rigid Reservoir	563590	Straight					
Pump with 6# Rigid Reservoir	563593	Elbow					
Pump with 6# Rigid Reservoir	563888	Elbow	12 VDC				
Pump with 6# Rigid Reservoir	563854	Straight	12 VDC	24W479	Yes	Yes	Yes
Pump with 12# Rigid Reservoir	563874	Straight	12 VDC	24W479	Yes	Yes	Yes

Ordering Information

Grease Jockey Pump Accessories	
24W482	Grease Jockey digital timer
24W479	Grease Jockey digital timer with Delphi 56 connector
24W480	Grease Jockey digital timer with Delphi 280 connector
25A118	Grease Jockey digital timer with flying leads
25A044	Service startup and spares kit
557932	12 VDC replacement solenoid
563641	12 VDC replacement solenoid kit with 1/4" NPT(m) fitting
24E017	24 VDC replacement solenoid

On-Road Mobile Lubrication Systems

Grease Jockey®

Grease Jockey Right and Left Front Kits for Trucks

	# of Grease Points	Part Number	Upper King Pin	Lower King Pin	Drag Link	Drag Link	Slack Adjuster	S-Cam	Tie Rod	Spring Pin	Spring Hanger-Upper	Spring Hanger-Lower	Steer Assist	Steer Assist	Clutch Pedal	Clutch Cross Shaft-Right	Clutch Cross Shaft-Left	Clutch Throw Out Bearing	
			Right Front																
			Injector Size																
Right Front Kit	5	563727							2										
Right Front Kit	5	563860		3			1	0	2										
Right Front Kit	7	563859	3	3			1	0	2							0	0		
Right Front Kit	8	563652	3	3			1	0	2	3	3	3							
Right Front Kit	8	563715	3	3			1	0	2							0	0	0	
Right Front Kit	8	563858	3	3			1	0	2	3	3	3							
Right Front Kit	10	563645	3	3			1	0	2	3	3	3				0	0		
			Left Front																
Left Front Kit	5	563728	3	3	2	2			2										
Left Front Kit	7	563706	3	3	2	2	1	0	2										
Left Front Kit	8	563716	3	3	2	2	1	0	2						0				
Left Front Kit	10	563644	3	3	2	2	1	0	2	3	3	3							

Grease Jockey Rear Axle Modules Truck and Tractor Kits

	# of Grease Points	Part Number	Slack Adjuster	S-Cam	Slack Adjuster	S-Cam	Rear Spring	Slack Adjuster	S-Cam	Slack Adjuster	S-Cam	Rear Spring	5th Wheel Pivot-Right	5th Wheel Pivot-Left	5th Wheel Pivot Inner-Right	5th Wheel Pivot Inner-Left	Boom Pivot-Right	Boom Pivot-Left	5th Wheel Cylinder Upper-Right	5th Wheel Cylinder Upper-Left	5th Wheel Interlock	5th Wheel Plate	Front Right	Front Left	Rear Right and Left
			Right Rear				Left Rear				5th Wheel														
			Injector Size																						
Single Axle Kit	4	563647	1	0				1	0																
Single Axle Kit	6	563738	1	0				1	0								4	4							
Tandem Axle Kit	8	563646	1	0	1	0		1	0	1	0														
Tandem Axle Kit	10	563743	1	0	1	0		1	0	1	0						4	4							
Fifth Wheel Kit	6	563653											4				4		4	4		8	8		
Fifth Wheel Kit	6	563659											4				4	4	4					8	8
Fifth Wheel Kit	8	258248											4	4			4	4				8	8	8	8
Fifth Wheel Kit	10	563737											4	4			4	4	4	4		8	8	8	8
Fifth Wheel Kit	12	563744											4	4	4	4	4	4	4	4		8	8	8	8
Fifth Wheel and Single Axle Kit	11	563748	1	0			3	1	0			3								1	8	8	8	8	8
Fifth Wheel and Single Axle Kit	12	563717	1	0			3	1	0			3	1	1							8	8	8	8	8

On-Road Mobile Lubrication Systems

Grease Jockey®

Grease Jockey Pneumatic Universal Truck Kits

Kits include 6# pump kit (563854) and factory-configured injector manifold modules.

	# of Grease Points	Part Number	Upper King Pin	Lower King Pin	Slack Adjuster	S-Cam	Tie Rod	Spring Pin	Spring Hanger-Upper	Spring Hanger-Lower	Clutch Cross Shaft	Clutch Cross Shaft	Clutch Throw Out Bearing	"A" Frame Pivot	Lift Cylinder Top Pivot	Lift Cylinder Bottom Pivot	Slack Adjuster	S-Cam	Slack Adjuster	S-Cam	Rear Spring	Lift Cylinder Top Pivot	
			Right Front											Right Rear									
			Injector Size																				
Single Axle Tractor Kit	27	563897	3	3	1	0	2				0	0	0				1	0				3	
Single Axle Tractor Kit	28	563891	3	3	1	0	2				0	0	0				1	0				3	
Spotter Truck Kit	35	563823	3	3	1	0	2	3	3	3				8	8	3	1	1				3	
Tandem Axle Tractor Kit	33	563846	3	3	1	0	2	3	3	3	0	0					1	0	1	0			
Tandem Axle Tractor Kit	34	563809	3	3	1	0	2	3	3	3							1	0					
Tandem Axle Tractor Kit	34	563814	3	3	1	0	2	3	3	3	0	0					1	0	1	0			

Injector Size Key

Injector Size	0	1	2	3	4	8
Output Volume (cu in)	0.002	0.005	0.009	0.012	0.015	0.024

Truck and tractor lubrication systems lubricate these parts:

- A** Upper/Lower King Pins
- B** Hood Pins
- C** Spring Pins
- D** Drag Links
- E** Tie Rod Ends
- F** Slack Adjusters
- G** S-Cams
- H** Spring Hangers
- I** Clutch Pedal
- J** Clutch Cross Shafts
- K** Clutch Throw Out Bearing
- L** 5th Wheel Plate
- M** 5th Wheel Pivots
- N** Pump
- O** Right Front Module
- P** 5th Wheel Module
- Q** Left Front Module
- R** Rear Module

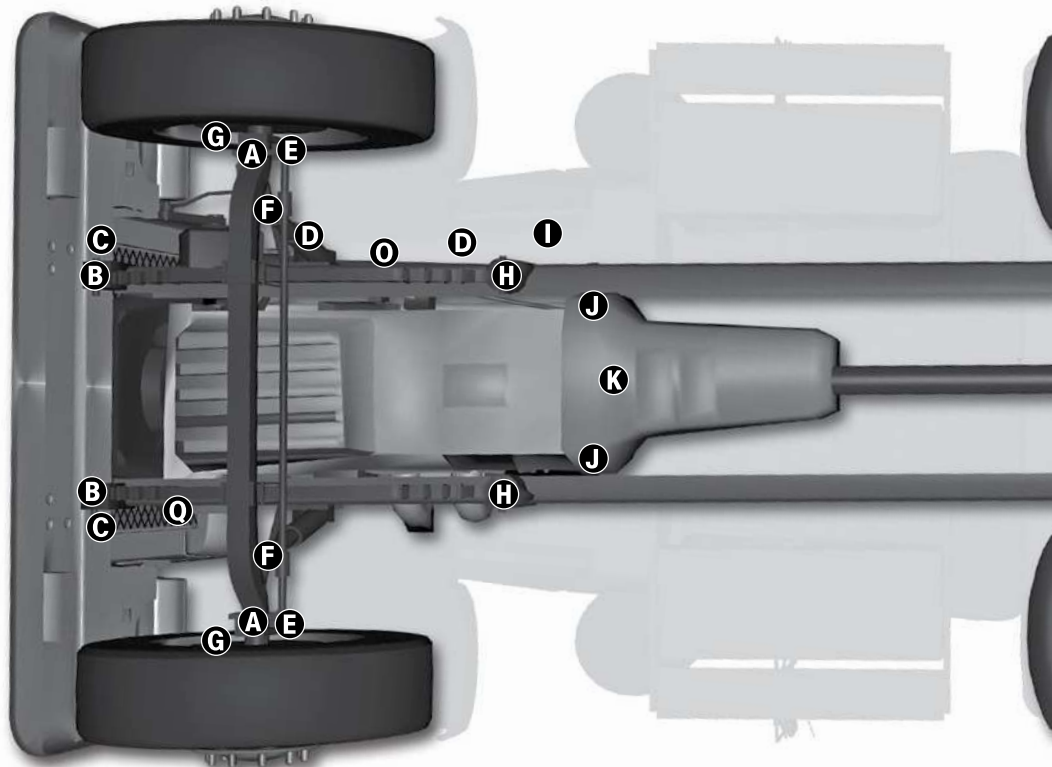

On-Road Mobile Lubrication Systems

Grease Jockey®

		Injector Size																							
		Left Front					Left Rear					5th Wheel													
		3	3	2	2	1	0	2				1	0		3						2	8	8	8	8
Upper King Pin																									
Lower King Pin																									
Drag Link-Front																									
Drag Link-Back																									
Slack Adjuster																									
S-Cam																									
Tie Rod																									
Spring Pin																									
Spring Hanger-Upper																									
Spring Hanger-Lower																									
Clutch Pedal																									
Clutch Cross Shaft																									
Clutch Throw Out Bearing																									
Lift Cylinder Top Pivot																									
Lift Cylinder Bottom Pivot																									
Slack Adjuster																									
S-Cam																									
Slack Adjuster																									
S-Cam																									
Rear Spring																									
Lift Cylinder Top Pivot																									
5th Wheel Pivot-Right																									
5th Wheel Pivot-Left																									
Boom Pivot-Right																									
Boom Pivot-Left																									
5th Wheel Cylinder (Up. R.)																									
5th Wheel Cylinder (Low. R.)																									
5th Wheel Cylinder (Up. L.)																									
5th Wheel Cylinder (Low. L.)																									
5th Wheel Interlock																									
5th Wheel Plate																									
5th Wheel Plate																									
5th Wheel Plate																									
5th Wheel Plate																									

